

OpenAir™

## Fast running actuators for air dampers

GNP19..



### Fast runner rotary version with electronic fail-safe function, AC/DC 24 V

- Electromotoric actuator for 2-position, 3-position, or modulating control
- Nominal torque 6 Nm at 2 s running time
- With electronic fail-safe function
- Self-centering shaft adapter
- Range mechanically adjustable between 0...90°
- Prewired with 0.9 m long standard connection cables
- GNP196.1E with adjustable auxiliary switches for auxiliary functions

**Use**

- For damper areas up to ca. 1 m<sup>2</sup>, friction dependent
- For air technology applications within building technology
- For laboratory fume hoods, etc.
- Suitable for use with continuous, 2-position, or 3-position controllers



The GNP19..1E actuator is **not** suitable for applications in railway vehicles.

**Functions**

<b>DIL switch setting</b>		A DIL switch is used to set the actuator's functionality.					
	Factory setting	Modulating control		2-position control		3-position control	
		<b>DC 0...10 V</b> 	<b>DC 2...10 V</b> 	<b>0...20 mA</b> 	<b>4...20 mA</b> 	<b>2-Pt</b> 	<b>3-Pt</b> 
<b>Position indication</b>							
	Mechanical	Rotary angle position					
	Electrical	Output voltage U = DC 0...10 V is generated proportional to rotary angle. U depends on the DIL switch's rotary direction position.					
<b>Rotary angle limitation</b>		The rotary angle of the shaft adapter can be limited mechanically to 5° increments.					
<b>GNP196.1E auxiliary switch</b>		The switching points for auxiliary switches A and B can be set mutually independent in 5° increments from 0...90°.					

## Type summary

Type	Power	Auxiliary switch	Torque	Holding torque	Damper size	Runtime
GNP191.1E <sup>1)</sup>	AC/DC 24 V	No	6 Nm	Reduced	Ca. 1 m <sup>2</sup>	2 s
GNP196.1E <sup>2)</sup>		Yes				

<sup>1)</sup> Approbation: CE, UL

<sup>2)</sup> Approbation: CE



When installing and operating a rotary actuator type GNP.. in low-noise environments, check the acoustic response of the actuators operated together with the measuring and control equipment.

The combination with differential pressure sensors, sensors, and controllers may result in unwanted operational noise based on the operating settings, regardless of the given manufacturer.

Impacted applications:

- • Low-noise HVAC plants in general <sup>1)</sup>
- • Supply and extract air plants
- • Fume hood control plants
- • Room pressure control plants

**Alternative:** We recommend using rotary actuator HLV40.1 if the applications listed above are motorized or in the event of any general concerns regarding operational noise of GNP.. actuators (contact your local Siemens representative).

<sup>1)</sup> E.g. laboratories / fume hoods, hospital rooms or similar plants

### Factory setting

The actuator is preset at the factory to:

- 0...10 V
- Clockwise rotary movement
- Counter-clockwise fail-safe movement

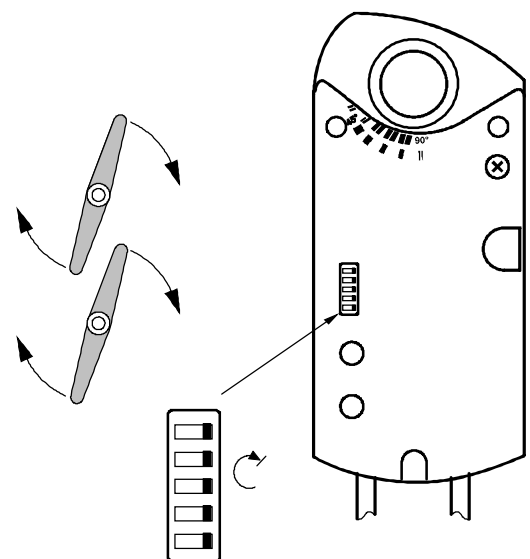

## Scope of delivery

Individual parts such as shaft adapter with position indication and other mounting materials for the actuator are delivered **unassembled**.

## Accessories / Spare parts

Various accessories are available to extend the actuators' functionality; e.g. rotary/linear mounting kit, external auxiliary switch (1 or 2 switches) and weather shield; see data sheet **N4697**.

## Product documentation



Content	Title	Document ID
Mounting instructions	Drehantrieb GAP19..1E, GNP19..1E	M4608
Data sheet	Accessories and spare parts for air damper actuators	N4697

Related documents such as the environmental declarations, CE declarations, etc., can be downloaded from the following Internet address:

<https://siemens.com/bt/download>

## Notes

### Safety

 <b>CAUTION</b>	
	<p><b>National safety regulations</b></p> <p>Failure to comply with national safety regulations may result in personal injury and property damage.</p> <ul style="list-style-type: none"><li>● Observe national provisions and comply with the appropriate safety regulations.</li></ul>

### Disposal

	<p>The device is considered an electronics device for disposal in terms of European Directive 2012/19/EU and may not be disposed of as domestic garbage.</p> <ul style="list-style-type: none"><li>● Dispose of the device through channels provided for this purpose.</li><li>● Comply with all local and currently applicable laws and regulations.</li></ul>
---	---

Power		
Operating voltage (SELV/PELV)		AC/DC 24 V $\pm$ 20 %
Frequency		50 Hz / 60 Hz
Power consumption	Running	20 VA / 13 W
	Holding	5 W

Functional data		
Torque	Nominal torque	6 Nm
	Maximum torque (when blocked)	18 Nm
Rotary angle	Nominal rotary angle	90°
	Maximum rotary angle	95° $\pm$ 2°
Runtime for 90° rotary angle		2 s (50 Hz)

Inputs		
Positioning signal Y/Y1		
	Input voltage Y/Y1+ (wires 8-2)	DC 0 (2)...10 V / 0 (4)...20 mA or AC/DC 0 V, AC/DC 24 V "open"
	Positioning resolution DC 0 (2)...1 V / 0 (4)...20 mA	250 steps for 90°
	Maximum permissible input voltage	AC/DC 24 V $\pm$ 20 %
Positioning signal Y2		
	Input voltage Y2+ (wires 7-2)	AC/DC 0 V, AC/DC 24 V "close"
	Maximum permissible input voltage	AC/DC 24 V $\pm$ 20 %

Outputs		
Position indicator		
	Output voltage U (wires 9-2)	DC 0 (2)...10 V
	Maximum output current	DC $\pm$ 1 mA

Auxiliary switch (GNP196.1E)	
Contact loading	6 A resistive, 2 A inductive
Voltage (no mixed operation AC 24 V / AC 230 V)	AC 24...230 V
Switching range for auxiliary switches	5°...90°
Setting increments	5°

Connection cable	
Cable length	0.9 m
Cross-sectional area	0.75 mm <sup>2</sup>

Housing type and protection class	
Insulation class	EN 60730
	AC 230 V, auxiliary switch II
Housing protection class	IP54 as per EN 60529 (observe mounting notes)

Environmental conditions	
Operation	IEC 60721-3-3
	Temperature -18...50 °C
	Humidity (non-condensing) <95 % r.h.
Transportation	IEC 60721-3-2
	Temperature -32...70 °C
	Humidity (non-condensing) <95 % r.h.

Norms and directives	
Product safety:	EN 60730-2-14 Automatic electronic controls for household and similar use (Type 1)
Electromagnetic compatibility (Application)	EN IEC 16000-6-2:2019 Immunity standard for industrial environments  EN IEC 16000-6-4:2019 Emission standard for industrial environments
EU Conformity (CE)	A5W00004382 <sup>1)</sup>
RCM Conformity	A5W00004383 <sup>1)</sup>
UL	GNP191.1E As per UL 60730 <a href="http://ul.com/database">http://ul.com/database</a>
	GNP196.1E -
cUL	GNP191.1E As per CSA-C22.2 No. 24-93
	GNP196.1E -

### Environmental compatibility

The product environmental declaration CE1E4608en <sup>1)</sup> contains data on environmentally compatible product design and assessments (RoHS compliance, materials composition, packaging, environmental benefit, disposal).

### Dimensions

Actuator B x H x T		81 x 192 x 63 mm (see Dimensions [► 9])
Damper shaft	Round	6.4...20.5 mm
	square	6.4...13 mm
	Minimum shaft length	20 mm
Weight	Excluding packaging	1.230 kg

<sup>1)</sup> The documents can be downloaded at <http://siemens.com/bt/download>.

## Connection diagrams

### Internal diagrams

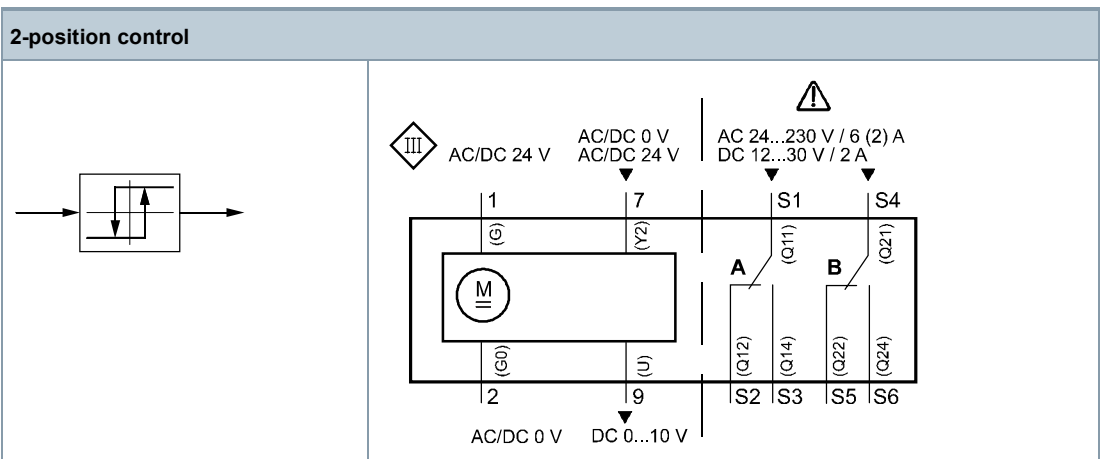
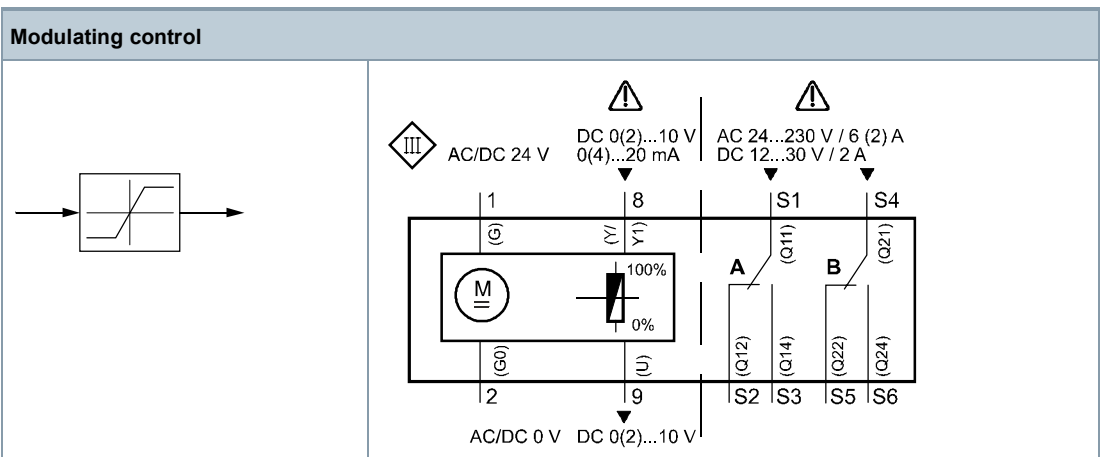

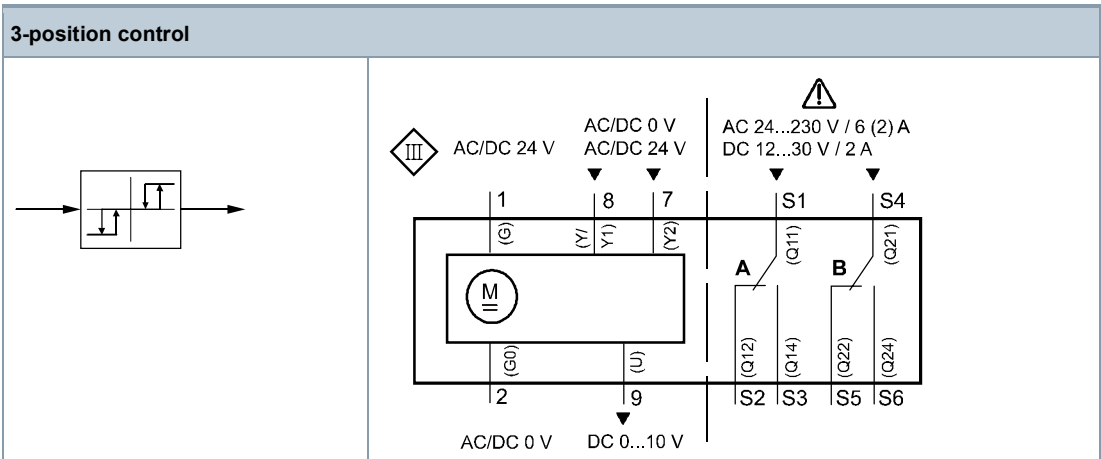

## Connection diagrams

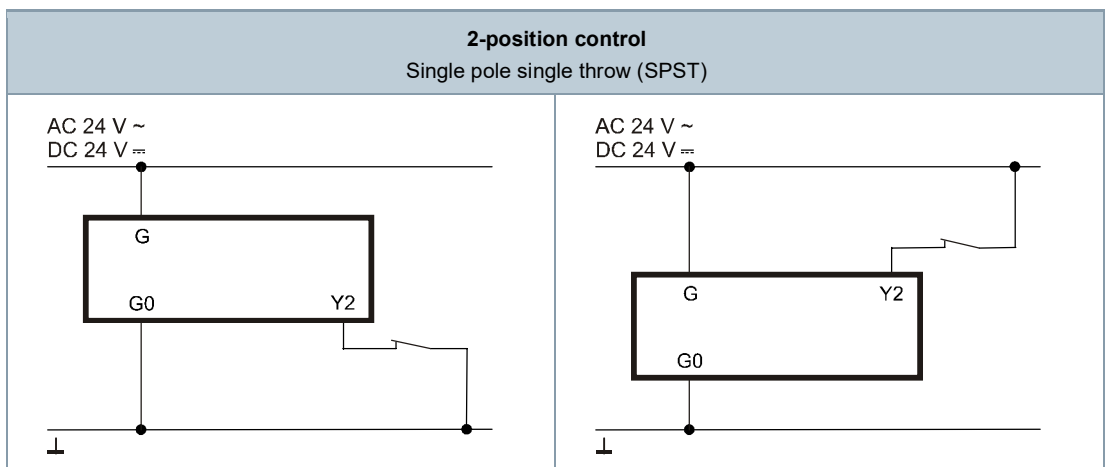

## Cable designations

Pin	Cable				Meaning
	Code	No.	Color	Abbreviation	
Actuators AC/DC 24 V	G	1	Red	RD	System potential AC/DC 24 V
	G0	2	Black	BK	System neutral
	Y2	7	Orange	OG	Positioning signal AC/DC 0 V, AC/DC 24 V "close"
	Y/Y1	8	Gray	GY	Positioning signal DC 0 (2)...10 V 0 (4)...20 mA or Positioning signal AC/DC 0 V, AC/DC 24 V "open"
	U	9	Pink	PK	Position indication DC 0 (2)...10 V
Auxiliary switch	Q11	S1	Gray/red	GYRD	Switch A Input
	Q12	S2	Gray/blue	GYBU	Switch A Normally closed contact
	Q14	S3	Gray/pink	GYPK	Switch A Normally open contact
	Q21	S4	Black/red	BKRD	Switch B Input
	Q22	S5	Black/blue	BKBU	Switch B Normally closed contact
	Q24	S6	Black/pink	BKPK	Switch B Normally open contact



## Dimensions

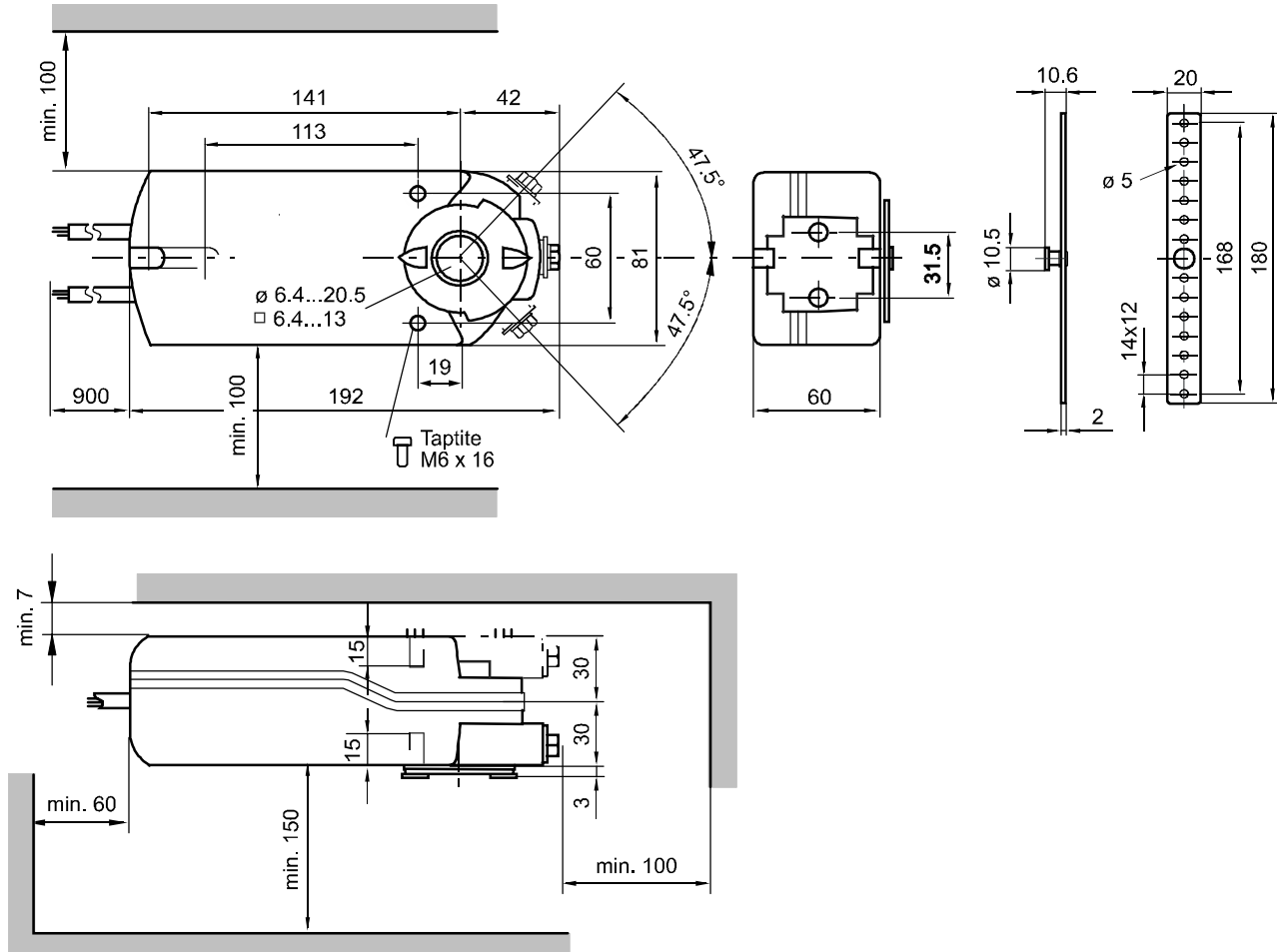

Dimensions in mm